

QUALIKAP QKP-N

Capsule con membrana in Nylon 6,6

- Testable in situ
- Sterilizable in autoclave
- Sanitizable
- Thermowelded assembly
- EC-listed materials for food contact
- FDA-listed materials per CFR21
- Extractables as per USP for plastic materials
- Validation Guide available
- Low extractable



QUALIKAP QKP-N capsules are especially designed to be used as sterilizable final filter for small batches in pharma applications. QUALIKAP QKP-N are fitted with Nylon 6,6 membrane whose porosity guarantees high bacterial retention efficiency.

Typical applications are alcoholic solutions, ultra pure water, vaccines, physiological solutions, ophthalmic solutions, etc.

The manufacturing is done in a controlled environment; each filter element is tested to verify the integrity. Each capsule is supplied with conformity test certificate showing the lot.

MATERIALS OF CONSTRUCTION

Membrane	Nylon 6,6 membrane
Upstream drainage layers	Polyester
Downstream drainage layers	Polyester
Core and Cage	Polypropylene
Outer Shell	Polypropylene
Terminals	Polyester

FOOD-SAFETY

QUALIKAP-QKP-N capsules meet (EU) regulation 10/2011 and its subsequent amendments and regulations (EC) 1935/2004 and 1895/2005.

BIO-SAFETY AND EXTRACTABLES

- Materials are compliant to USP-VI CLASS toxicological requirements and USP-Plastic Materials chemical and physical requirements.
- Capsule filters meet USP "Water for injection" requirements for endotoxin particle release; the bacterial endotoxin are determined using LAL Test.
- Extractable NVR (gravimetric) after autoclave ≤ 2 mg.
- TOC and conductivity according USP "Purified water" and "Water for Injection" requirements.

RECOMMENDED OPERATING CONDITIONS

- steam sterilization (no in line sterilization available)	in autoclave up to 135 °C *
- max. pressure	5 bar at 40 °C - 5,5 bar at 25 °C
- chemical sanitization	Compatible with a wide range of sanitizers
- forward flow max. differential pressure	4,5 bar at 40 °C - 1,0 bar at 80 °C
- reverse flow max. differential pressure	3,5 bar at 40 °C
- recommended pressure drop for changeover	2,0 bar at 25 °C
- in situ recommended flushing volume	1 liter

CODE	ABSOLUTE FILTRATION GRADE IN LIQUIDS	BACTERIAL REDUCTION CHARGE $>10^7$ CFU/cm ² **	ACCEPTANCE LIMIT FOR DIFFUSION TEST (ml/min)
CY	0,2 µm	Brevundimonas Diminuta	≤ 8.0 @ 2,1 bar
CYY	0,2 µm double	Brevundimonas Diminuta	≤ 8.0 @ 2,1 bar

* Operational limits and usage conditions available upon request

** BACTERIAL RETENTION TEST as per ASTM F838-05

WATER FLOW RATE CHARTS

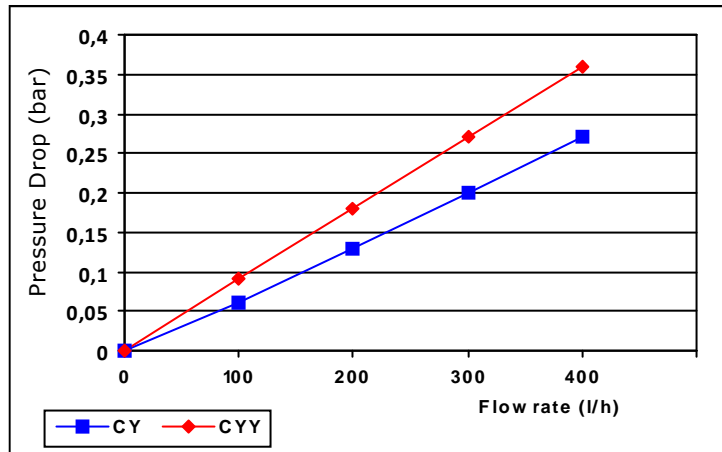

QUALIKAP QKP-N ORDERING INFORMATION

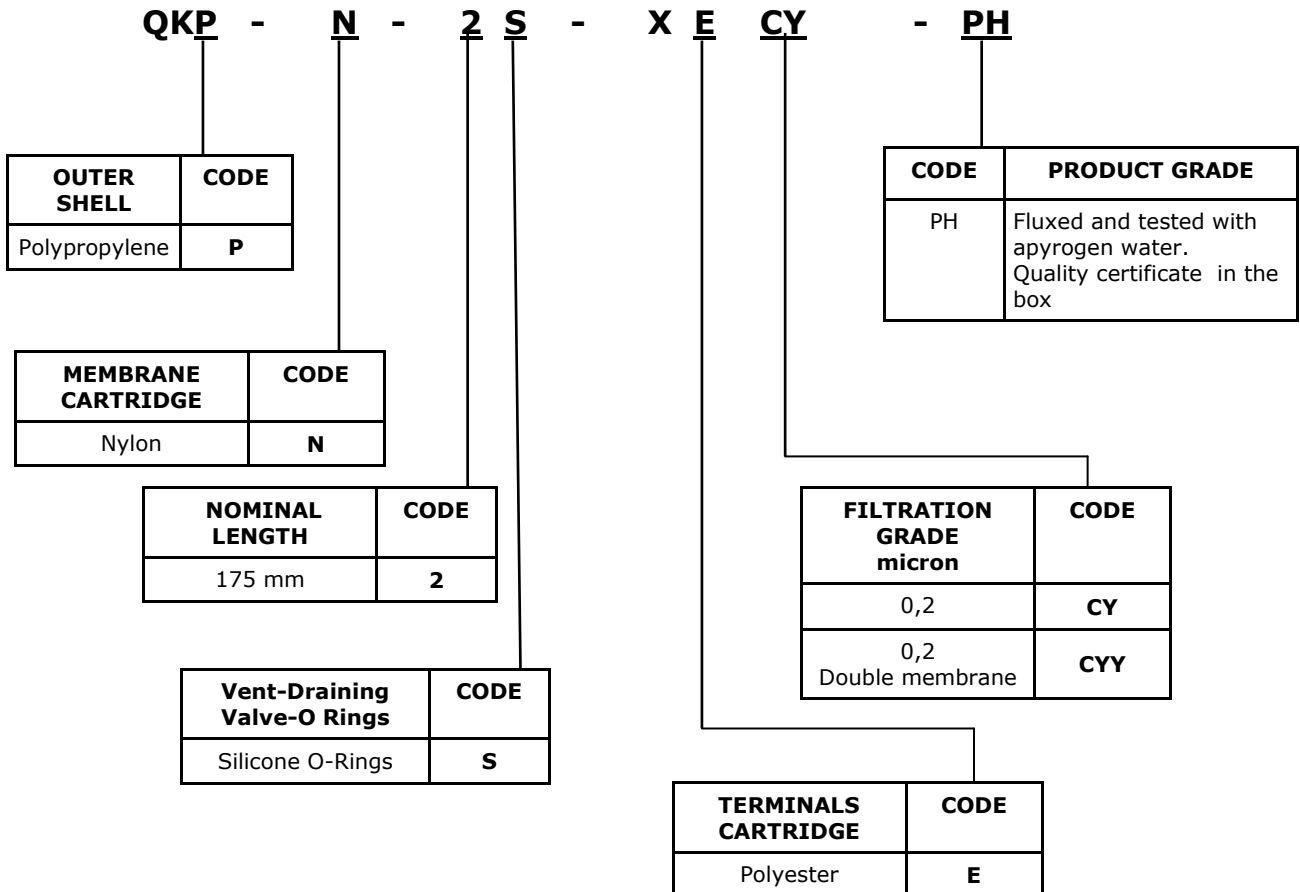

- Max diameter (valves included): 117 mm
- Tri-clamp connections 1 1/2"

Data contained in this bulletin are informative and subject to change without notice.
 User is responsible for determining whether the product is fit for particular purpose and suitable for User's method of application.



Bea Technologies Spa Via Newton, 4 - 20016 Pero (Milano) ITALY
 Tel +39 02 339271 FAX +39 02 3390713 e-mail: info@bea-italy.com
 web: www.bea-italy.com